

OUTLINE DRAWING

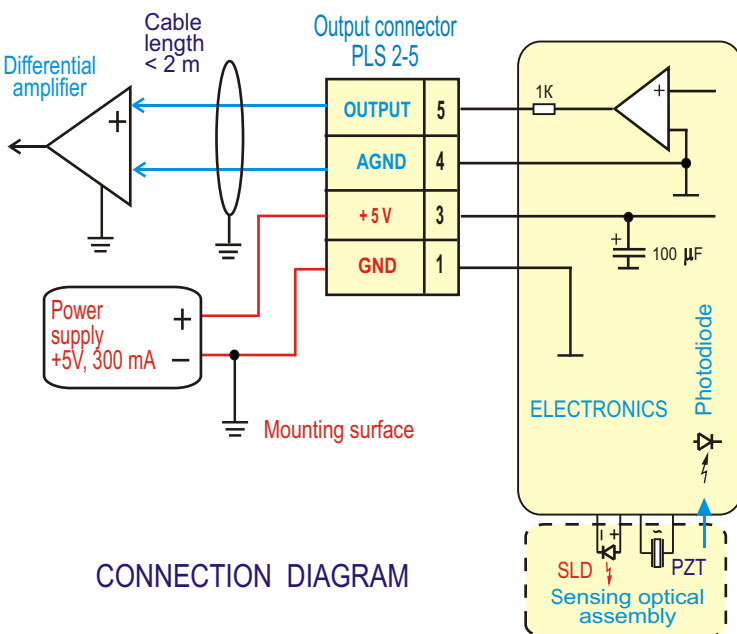

CONNECTION DIAGRAM

MAIN PARAMETERS

◆ Rate range	300 deg/s
Scale Factor (SF)	12 mV/deg/s
Frequency range	0... 0.45 kHz
Angle random walk	0.03 deg /√h
Bias stability (steady state)	15 deg / h (RMS)
SF variation (steady state)	0.1 % (RMS)
Readiness time	0.1 s

ENVIRONMENT

Temperature operating	-30°C ... +70°C
endurance	-55°C... +85°C
Vibration (operating)	2 g (RMS), 20Hz... 500Hz
Vibration (endurance)	6 g (RMS), 20Hz... 2000Hz
Shocks (endurance)	90 g, 1 ms
Acceleration (operating)	5 g
Acceleration (endurance)	20 g, 5 s

RELIABILITY

MTBF	20000 hours (20°C, predicted)
Lifetime (predicted)	15 years

- ◆ Rate range (measurement) - grade 4.0 (linearity error - 4%)
- ◆◆ Rate range (indication) -400 deg/s (min) (linearity error - 15%)

Output connector PLS2-5

Contact	Name	Description
1	GND	Power return line, ground
2	KEY	Shortened pin
3	+ 5 V	Power input +5V ± 0.25V, 300mA max, ripple 10mV max within 0-1MHz
4	AGND	Analog ground to use with "OUTPUT". Differential input recommended. Galvanic coupling with "GND".
5	OUTPUT	Output voltage proportional to rotation, scale factor 12 mV/deg/sec. Differential input recommended.

MOUNTING AND CONNECTING

1. Do not deform housing and output pins
2. Fragile components inside - no shocks, no drop
3. Treat as electrostatic sensitive unit
4. Mounting surface must be grounded
5. Power must be off during connecting
6. Soldering to contacts by low-temperature solder

1. Ω - sensing axis, $90^\circ \pm 1^\circ$ to the reference plane
2. Dissipation - 1 W
3. Weight - 80 gram (100 gram max)
4. Volume - 0.05 litre
5. Housing material - aluminum alloy
6. Tolerances - ± 0.5 IT14